

Angle Fire Pump Relief Valve Gr x Gr Ends

FIG. F1329

Specifications

- Grooved Ends to AWWA C606 Standard.
- Opens quickly; maintains pressure within close limits.
- Wide range adjustable: 65psi - 300psi (4.5 bar - 21 bar).
- Pilot operated main valve.
- Reduced cavitation design.
- Simple field adjustable pressure setting, requiring no special tools or system down time.
- Closes gradually for surge-free operation.
- UL 1478 Listed and FM 1361 Approved.
- Limits maximum pump discharge pressure.
- Factory tested & preset to requirements.
- Applicable for water, foam.
- 300psi (21bar) high Working Pressure
600psi (42bar) Hydrostatic Test
- Fusion Bonded Epoxy Coated Interior and Exterior to AWWA C550 Standard.

Material Specifications

Main Valve Parts	Material	ASTM Specification
Body	Ductile Iron	A536 Grade 65-45-12
Seat	Stainless Steel	A351 Grade CF8
Seal Disc	Rubber	D2000 EPDM
Diaphragm	Nylon Reinforced Natural Rubber	
Diaphragm Disc	Ductile Iron	A536 Grade 65-45-12
Diaphragm Adapter	Ductile Iron	A536 Grade 65-45-12
Spring	Stainless Steel	A276 Type 304
Bonnet	Ductile Iron	A536 Grade 65-45-12
Bonnet Bolts	Carbon Steel	A307 Grade B
Stem	Stainless Steel	A276 Type 304
O-Ring	Rubber	D2000 NBR

No.	Trim Components	Material
1	Basic Control Valve Assembly	Assembly
2	Pressure Relief Pilot Assembly	Assembly
3	Ejector	Stainless Steel 304
4	Y-strainer	Stainless Steel 304
5	Tubing/Fittings	Stainless Steel 304
6	Check Valve	Stainless Steel 304
7	Stabilizer	Stainless Steel 304

Main Dimensions (mm / inch)

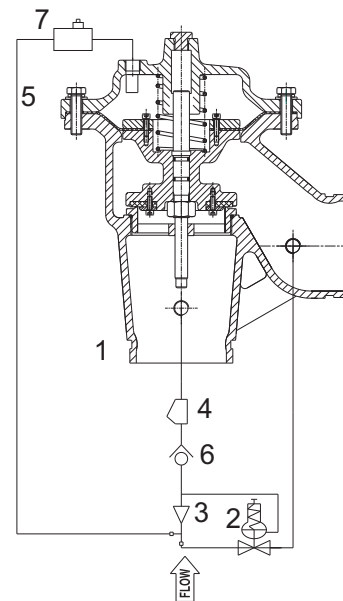
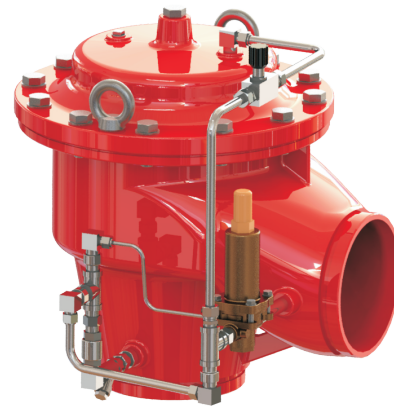
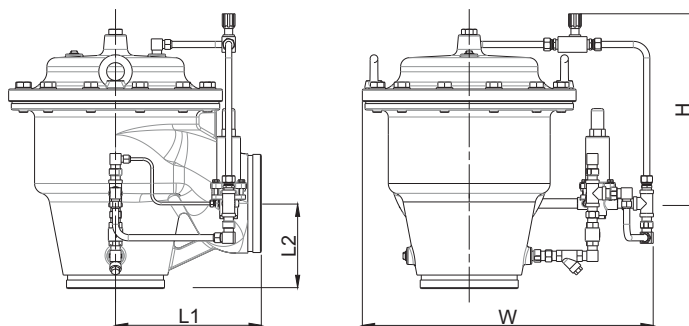

Size	L1	L2	H	W
3"	149/5.9	110/4.3	265/10.5	455/18.0
4"	185/7.3	130/5.1	310/12.2	470/18.5
5"	218/8.6	140/5.5	360/14.2	490/19.3
6"	265/10.4	155/6.1	380/15.0	540/21.3
8"	326/12.8	190/7.5	450/17.8	590/23.2

Notes

• Designs, materials and specifications shown are subject to change without notice due to the continuous development of our products.